



# MAINTENANCE TROUBLESHOOTING INTERNATIONAL LLC

LLC-302

Hands-On Training Center: 2860 Ogletown Road, Newark, DE 19711  
Corporate Offices & Mailing Address: 2917 Cheshire Road Wilmington, DE 19810  
Phone/TXT: 302.593.2698 (Frank) Email: Frank@mtroubleshooting.com  
Website: www.mtroubleshooting.com

## LLC-302 LADDER LOGIC CIRCUITRY: INCLUDING LADDER DRAWING, SCHEMATICS AND CONTROLS

Do you need to understand electrical drawings and schematics so you can service or troubleshoot your facility or industrial electrical system? If so, you will find this course extremely beneficial. This two-day course delivers an essential skill in the field of equipment maintenance, installation or modification: the ability to read and understand electrical ladder drawings, schematics and diagrams. The course covers several types of industrial control prints for a variety of different motor-driven processes, with an emphasis on the differences between type and the purposes and flow of each. Students will participate in exercises to create schematic diagrams based on circuit descriptions and will learn to interpret schematic drawings in order to provide verbal or written circuit descriptions.

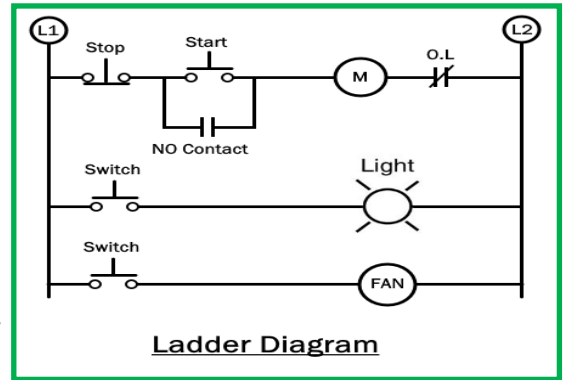

Ladder Diagram

### General Requirement for Electrical Safety-Related Work Practices

- Introduction, Types of Drawings and Symbols
- Importance and Relevance of Dwgs.
- Categories of Electrical Drawing and their Characteristics
- Purposes served by Different Type of Electrical Drawings
- International Electrical Symbols and Drawings
- Component Symbols
  - Wiring & Connections
  - Power Source
  - Breakers
  - Disconnects
  - Fuses
  - Fuse Block
  - Contactors
  - Overloads
  - Loads
  - Grounds
  - Others
- Applications and Functions of Numerical Relays
- Importance of CTs and VTs Information in Electrical Drawings

### Interpretation and Significance of Single Line Diagrams

- Onset of a Single Line Diagram
- Importance of Single Line Diagrams
- Standardized Drawing Symbols

- Protective Devices Coordination in Single Line Diagrams
- Fault Current Calculations with Information from the Single Line Diagram
- Troubleshooting and Electrical Installation with the Relevant Diagrams

### Ladder Diagrams Interpretation

- Types of Ladder Diagram
- Generic Electrical Equipment Ladder Diagrams
- Designing Control Circuits
- Interlock Control Circuits
- Protective Relays and Timers Ladder Diagrams
- Fail Safe Designs

### Schematic and Control Circuits

- VFD Schematics and its Operation related to Controlling Circuits
- UPS Power Supply Schematic Diagram Components Functionalities
- Reading and Tracing AC Input Diagrams and its Significance
- Identify Components in the Rectifier, Inverter and AC Outputs Schematic Diagrams
- Types of Protection Relays Schematics, Wiring, Operation and Functional Diagrams
- Motor Installation and Control Circuits

### Logic Circuit Applications and Troubleshooting Strategies

- Logic Gates and Characteristics
- Digital Logic Functions
- Programmable Logic Controllers
- Process and Instrument Diagrams

### Real-World Applications

- Conveyor Timing
- Air Compressors
- HVAC Controls
- Fluid Level Controls
- Material Handling Systems
- Process Temperature Controls
- Exterior Lighting Controls
- Generator Controls
- Chemical Process Controls
- Variable Frequency Drives

### CLASS FORMATS AVAILABLE

- MTI Hands-On Center \$995/person
- On-Site (Your Location) Ask for Quote

Quick Quote Available in 48 hrs.

### CLASS DURATION

2-days, 15 hours of instruction  
30% Hands-On

### FREE BOOK

MOTOR CIRCUITS (\$30)

**Class Details:** Each student will receive class books, work activity sheets, self-test progress evaluations, as well as questions from the instructor to make sure they understand the material presented. It is expected that an attendee will leave the class with the basic knowledge of the subject and possess new found skills to better equip them when they return to their job. A certificate suitable for framing will be issued to each attendee who successfully completes the course. Call, email or check the website for the next time this course is scheduled at the MTI training center or ZOOM interactive. On-site sessions? Request a quick 48-hour turnaround quote. Revised: 02/06/2021